

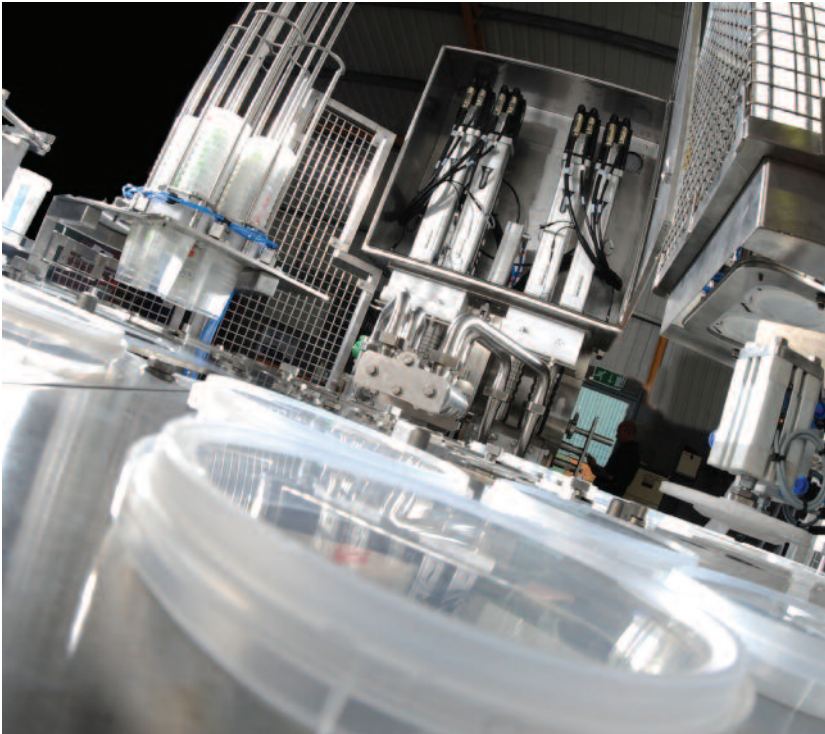

CWM Automation produce the highest quality packaging machinery and have provided innovative solutions to many successful companies

ROTARY MACHINES



CWM Automation offers a range of highly flexible ROTARY container filling, heat sealing and lidding machines. Manufactured in stainless steel, each ROTARY machine is meticulously designed and built to suit customers exact requirements.

Product and packaging changeovers can be carried out in under 10 minutes using the CWM quick-change format.

Open construction and easy access make CWM ROTARY machines operator-friendly and innovative hygienic designs allow easy cleaning.

Machine Types

Model	Description	Max. Output Speed
CWM 50R	Single head rotary machine	50 containers / minute
CWM 100R	Twin head rotary machine	100 containers / minute
CWM 200R	Four head rotary machine	200 containers / minute

Machine Services

Model	Power	Frequency	Loading	Pneumatics
CWM 50R	415V	50Hz	16A	5.5 bar
CWM 100R	415V	50Hz	25A	6 bar
CWM 200R	415V	50Hz	32A	6 bar

Machine Options

- Automatic Cup Loader with optional turnover/cup clean facility
- Up to 3 filling stations
- Filler Drive Options:- Servo, Pneumatic or Mechanical
- Wet or Dry Products
- CIP – Clean in Place
- Interchangeable nozzle types
- Product Tank Agitation
- Tank Level Probe
- Double Skin Tank
- Servo operated Fill Lift for decorative filling techniques
- On-screen real time adjustment of all machine settings
- Date Coder
- Bespoke outfeed conveyor configurations
- Rotary Accumulation Table



CWM 50R

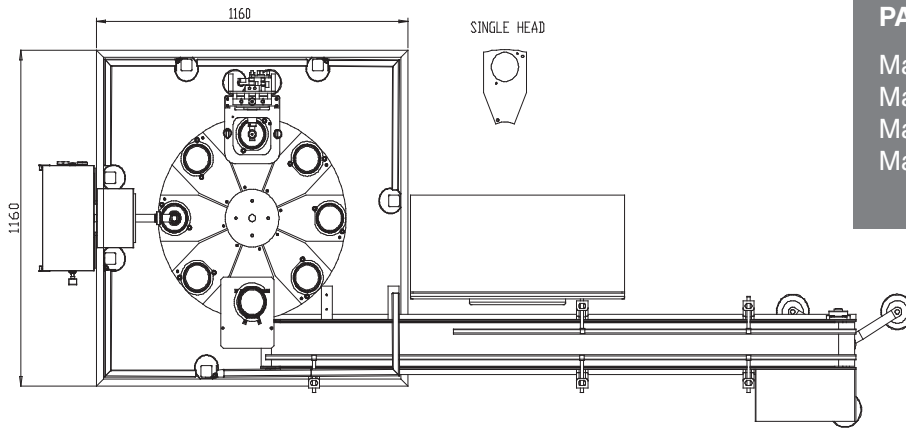

PACKAGING SPECIFICATION

Max pot diameter	135mm
Max pot depth	140 mm
Max fill volume	1000ml
Max particulate size	25mm ²

CWM 100R

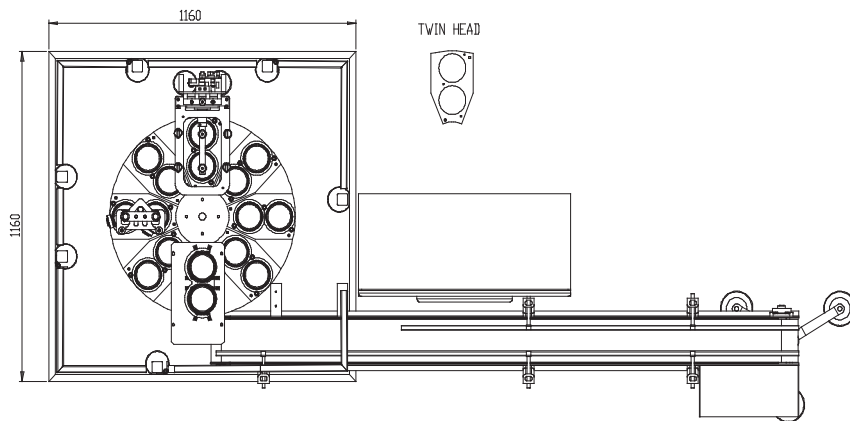

PACKAGING SPECIFICATION

Max pot diameter	105mm / 135mm *
Max pot depth	140 mm
Max fill volume	1000ml
Max particulate size	25mm ²

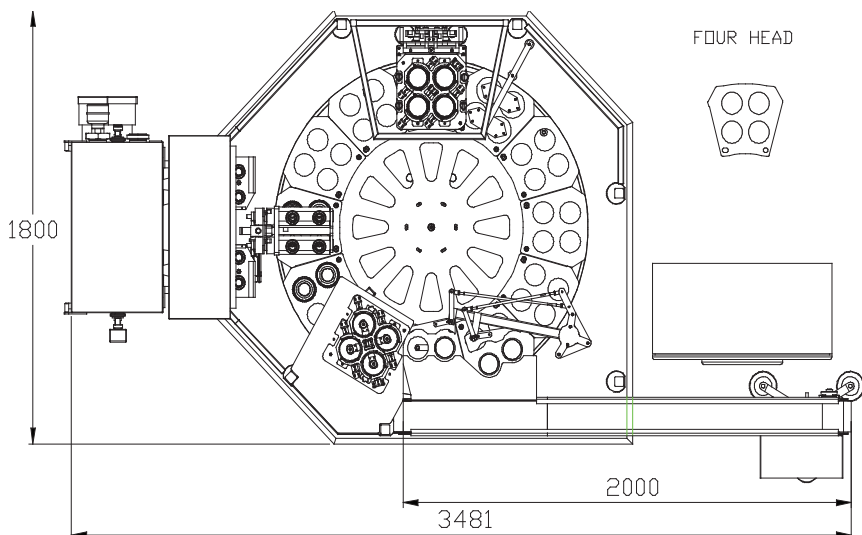

CWM 200R

PACKAGING SPECIFICATION

Max pot diameter	105mm / 135mm *
Max pot depth	140 mm
Max fill volume	1000ml
Max particulate size	25mm ²

* Denotes large frame machine layout



CWM AUTOMATION
machinery design, build & maintenance

Office: 133 Wenlock Road, Shrewsbury, SY2 6JZ
T: 05602 805616 **E:** info@cwm-automation.co.uk
Works Unit: Unit 3 Longwood Road, Gainsborough, DN21 1QB
T: 01427 614222