

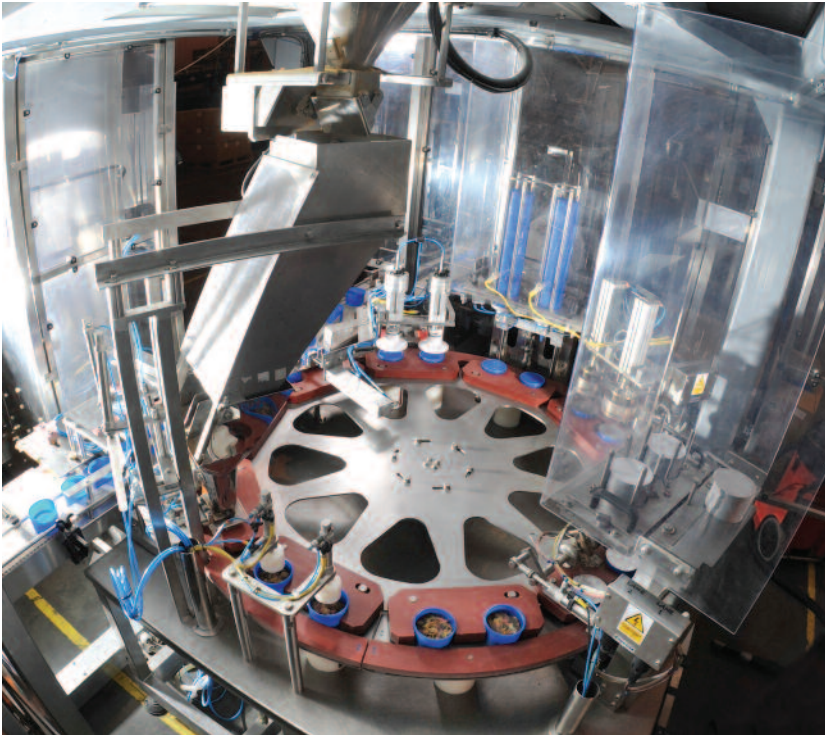

CWM Automation provides its customers with the expertise and support of one of the best teams in the industry

STARWHEEL MACHINES



CWM Automation offers a range of highly flexible STARWHEEL machines specifically designed to handle rigid walled, non-denestable packaging such as parallel sided containers, tubes, bottles or jars. STARWHEEL machines are ideally suited to the food, pharmaceutical, cosmetics and homecare sectors.

STARWHEEL machines can be also be fitted with automatic screw cappers and induction sealers offering ultimate flexibility in closure options

Machine Types

Model	Description	Max. Output Speed
ST 50R	Single lane Starwheel machine	50 containers / minute
ST 100R	Twin lane Starwheel machine	100 containers / minute

Machine Services

Model	Power	Frequency	Loading	Pneumatics
ST 50R	415V	50Hz	16A	5.5 bar
ST 100R	415V	50Hz	25A	6 bar

Machine Options

- Up to 3 filling stations
- Filler Drive Options:-Servo or Pneumatic
- Wet or Dry Products
- CIP – Clean in Place
- Interchangeable nozzle types
- Product Tank Agitation
- Tank Level Probe
- Can be integrated with a Screw Capper
- Option to fit an Induction Sealer
- On-screen real time adjustment of all machine settings
- Bespoke conveyor configurations
- Rotary Accumulation Table
- Turnkey Projects

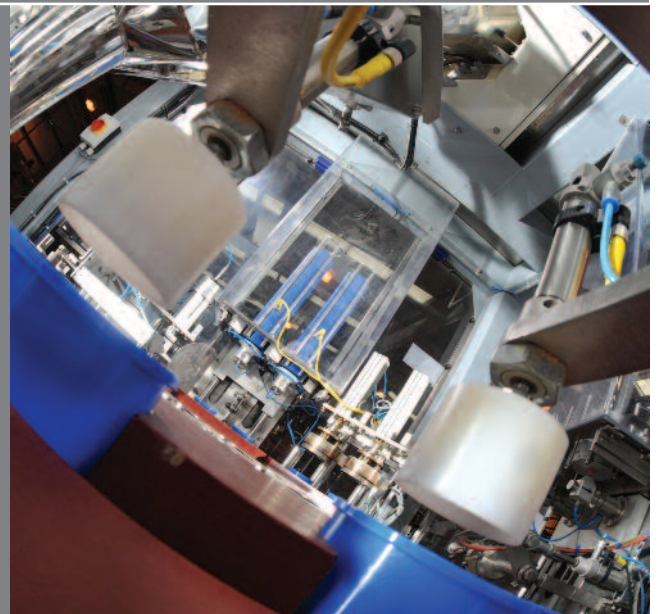

ST 50R SINGLE HEAD MACHINE

PACKAGING SPECIFICATION

Max pot diameter	135 mm
Max pot depth	200 mm
Max fill volume	1000 ml
Max particulate size	25 mm ²

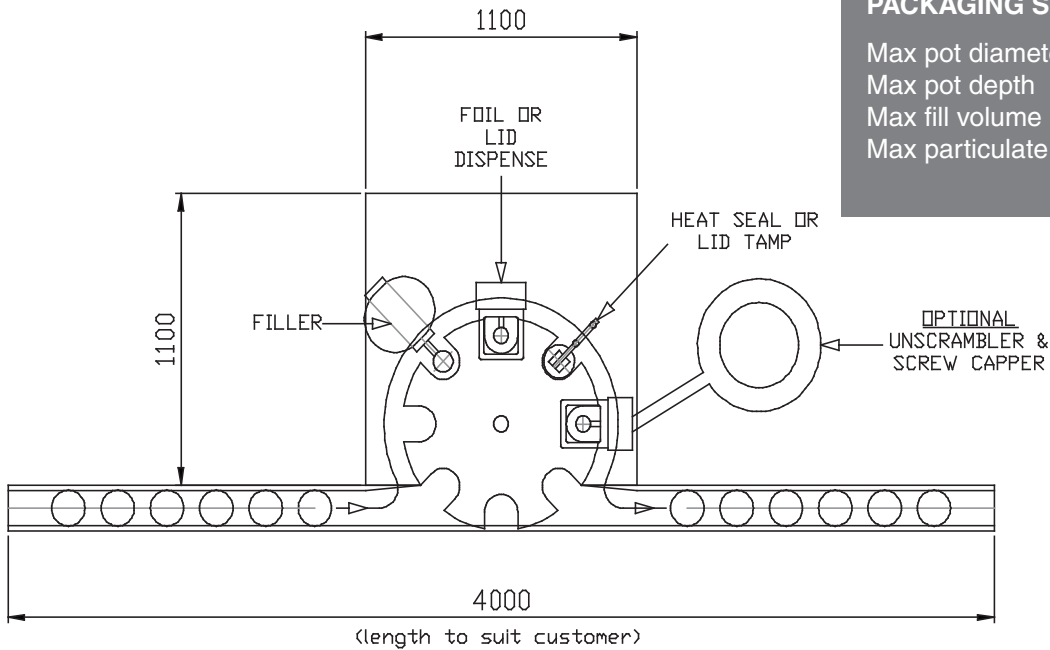

ST 100R TWIN HEAD MACHINE

PACKAGING SPECIFICATION

Max pot diameter	135 mm
Max pot depth	200 mm
Max fill volume	1000 ml
Max particulate size	25 mm ²

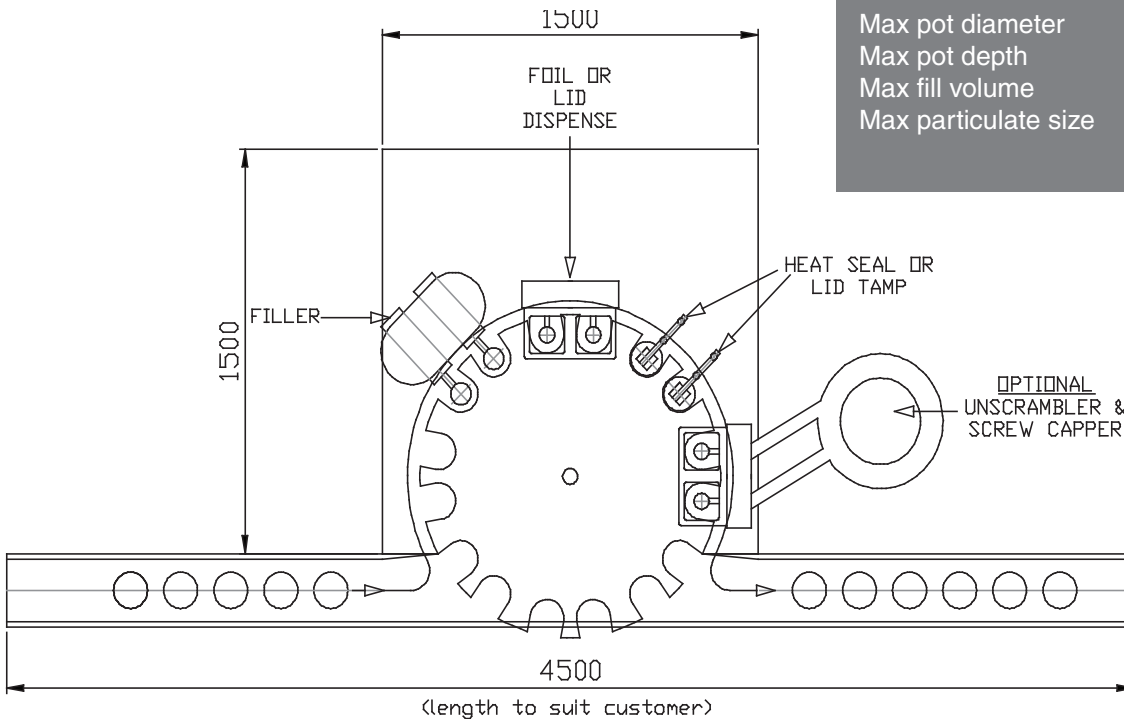

CWM AUTOMATION
machinery design, build & maintenance

Office: 133 Wenlock Road, Shrewsbury, SY2 6JZ
T: 05602 805616 **E:** info@cwm-automation.co.uk
Works Unit: Unit 3 Longwood Road, Gainsborough, DN21 1QB
T: 01427 614222